

# Estimation Of SIMHYD Parameter Values For Application In Ungauged Catchments

<sup>1</sup>Chiew, F.H.S. and <sup>1</sup>L. Siriwardena

<sup>1</sup>Department of Civil and Environmental Engineering, The University of Melbourne  
Email: [f.chiew@civenv.unimelb.edu.au](mailto:f.chiew@civenv.unimelb.edu.au)

**Keywords:** rainfall-runoff modelling, SIMHYD, parameters, calibration, regionalisation, Australia

## EXTENDED ABSTRACT

Rainfall-runoff models are used for various applications, ranging from the estimation of catchment water yield to the estimation of land use and climate change impacts on runoff characteristics. Most rainfall-runoff models can be calibrated successfully to reproduce the recorded runoff, however it is difficult to determine appropriate parameter values to use for modelling runoff in an ungauged catchment.

This paper describes the application of the lumped conceptual daily rainfall-runoff model, SIMHYD, on about 300 catchments across Australia. SIMHYD simulates daily runoff using daily precipitation and potential evapotranspiration as input data. SIMHYD is one of the most commonly used rainfall-runoff models in Australia, and is one of the rainfall-runoff models in RRL (Rainfall-Runoff Library) in the Catchment Modelling Toolkit.

The paper compares calibration results from several model types, investigates whether the calibrated parameter values can be related to catchment characteristics (model regionalisation), and compares the runoff modelled using parameter values estimated from the regionalisation relationships and obtained from the closest gauged catchment, with the recorded runoff.

The results indicate that SIMHYD can be calibrated satisfactorily to reproduce the monthly recorded runoffs. The use of the five-parameter version of SIMHYD is sufficient for most catchments, with Nash-Sutcliffe model efficiency values greater than 0.7 obtained in more than 90% of the catchments.

The model calibration method is designed to increase the likelihood of the optimised parameters taking meaningful values for the model regionalisation. The model is calibrated against

monthly runoffs to reduce errors associated with runoff routing, two constraints are used in the model calibration (the total modelled runoff must be within five percent of the total recorded runoff, and the quickflow ratio in the modelled runoff must be within 20% of the quickflow ratio in the recorded runoff), a five-parameter SIMHYD model is used rather than a seven-parameter model, and the two largest errors (difference between modelled and recorded monthly runoffs) in the model calibration are ignored in calculating the objective function.

The regionalisation results indicate that the correlations between the optimised parameter values and the catchment characteristics (climate, terrain, vegetation and soil properties) are statistically significant. However, the relationships are relatively poor, with the best relationship explaining about 25% of the variance, and the correlations for three of the five parameters explaining less than 10% of the variance. This is partly due to the significant cross-correlations between the model parameters.

The SIMHYD simulations using parameter values estimated from the regionalisation relationships are not consistently better than the simulations using parameter values obtained from the closest gauged catchment. The modelled monthly runoffs from both methods are reasonable in about three quarters of the catchments, where the Nash-Sutcliffe model efficiency is greater than 0.6 and the total modelled runoff is within 30% of the total recorded runoff.

It is likely that taking into account the parameter cross-correlations in the model calibration and constraining the model results to produce total runoff estimated from regionalised relationships between mean annual runoff and mean annual rainfall can lead to better modelling results for ungauged catchments.

## 1. INTRODUCTION

Rainfall-runoff models are used for various applications, ranging from the estimation of catchment water yield to the estimation of land use and climate change impacts on runoff characteristics (Singh and Frevert, 2002). Most rainfall-runoff models can be calibrated successfully to reproduce the recorded runoff, however it is difficult to determine appropriate parameter values to use for estimating runoff in an ungauged catchment. Many studies have attempted to relate the calibrated parameter values to catchment characteristics, commonly referred to as model regionalisation (Sivapalan et al., 2003; Blöschl, 2005). There is generally little success in these studies, because of errors in data (climatic inputs, runoff and catchment characteristics) and limitations in the model structure resulting in cross-correlations between parameters and different combinations of parameter values giving similar results in the model calibration (Beven, 2001).

This paper describes the application of the rainfall-runoff model, SIMHYD, on about 300 catchments across Australia. The paper investigates whether the calibrated parameter values can be related to the catchment characteristics. The paper also compares the quality of runoff estimates simulated using parameter values determined from the regionalisation relationships with those simulated using parameter values from the closest gauged catchment.

## 2. SIMHYD RAINFALL-RUNOFF MODEL

SIMHYD is a lumped conceptual daily rainfall-runoff model. SIMHYD simulates daily runoff (surface runoff and baseflow) using daily precipitation and potential evapotranspiration (PET) as input data. SIMHYD is one of the most commonly used rainfall-runoff models in Australia, and has been extensively tested using data from across Australia (Chiew et al., 2002). SIMHYD is one of the rainfall-runoff models in RRL (Rainfall-Runoff Library), a software product in the Catchment Modelling Toolkit ([www.toolkit.net.au/rrl](http://www.toolkit.net.au/rrl)).

The structure of SIMHYD and the algorithms describing water movement into and out of the storages are shown in Figure 1 (see Chiew et al., 2002, for a detailed description). There are seven parameters in SIMHYD, shown in bold italics and described at the bottom of the figure. The SIMHYD model used here also has a snow component, based on the concept of degree-day

(not shown here), but this is needed only for very few catchments for a very small part of the year.

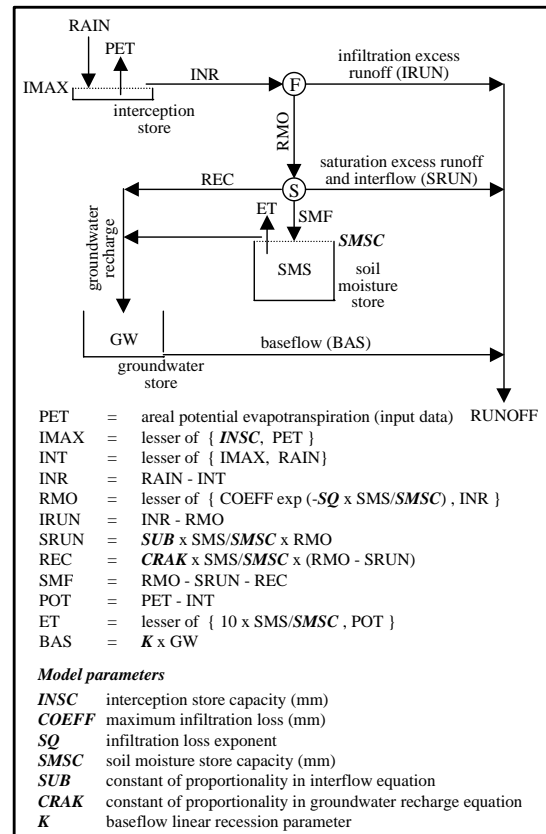

Figure 1. Structure of SIMHYD

## 3. DATA

The source of the data used for this study is the dataset of lumped catchment-average daily rainfall time series, mean monthly areal potential evapotranspiration (APET) and monthly streamflow time series for 331 unimpaired catchments collated for an Australian Land and Water Resources Audit project (Peel et al., 2000). The catchment areas range from 50 km<sup>2</sup> to 2000 km<sup>2</sup>.

Catchments with data that appear to be inconsistent are not used (runoff coefficient greater than 0.8, actual evapotranspiration (mean annual rainfall minus mean annual runoff) greater than 0.8 times mean annual APET, and clear inconsistency between monthly rainfall and runoff data), leaving 293 catchments for this study (see Figure 2). The catchments cover a large range of hydroclimatic and physical characteristics, are located in the more populated and important agricultural regions, and generally reflect the availability of long unimpaired streamflow data in Australia. A consistent modelling period between 1950 and 1998 is used for this study. The length of runoff

data available for model calibration range from 17 to 49 years (10<sup>th</sup> and 90<sup>th</sup> percentiles).

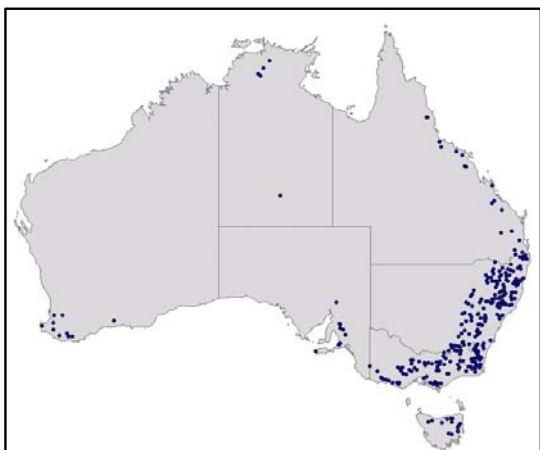

**Figure 2.** Locations of 293 catchment used in this study

Six catchment characteristics are used in the regionalisation study:

- Mean annual rainfall (mm) [RAIN] (provides an indication of the climate);
- Mean annual rainfall/APET [RAPET] (provides an indication of the climate);
- 90<sup>th</sup> percentile minus 10<sup>th</sup> percentile elevation (m) [TERR] (provides an indication of the terrain) – derived from AUSLIG nine second Digital Elevation Map of Australia;
- Fraction of total native woody vegetation [WOODY] (provides an indication of vegetation coverage) – from Barson et al. (2000) (see also [www.toolkit.net.au/liza](http://www.toolkit.net.au/liza));
- Plant available water holding capacity (mm) [PAWHC] (provides an indication of effective soil depth) – from McKenzie et al. (2000) (see also [www.toolkit.net.au/shpa](http://www.toolkit.net.au/shpa)); and
- Transmissivity (m<sup>2</sup>/day) [TRANS] (provides an indication of lateral flow rate) – from McKenzie et al. (2000) (see also [www.toolkit.net.au/shpa](http://www.toolkit.net.au/shpa)).

#### 4. MODEL CALIBRATION

SIMHYD runs on a daily time step, but is calibrated here against monthly runoff. This removes the need for routing and errors associated with routing. The parameters in the model are optimised to minimise an objective function defined as the sum of squares of the difference between the modelled and recorded monthly runoffs. Two constraints are used in the model calibration: the total modelled runoff must be within five percent of the total recorded runoff; and the quickflow ratio (surface runoff divided by

total runoff) in the modelled runoff must be within 20% of the quickflow ratio in the recorded runoff. The quickflow ratio in the daily recorded runoff series is determined using the Lyne and Hollick filter (Nathan and McMahon, 1990). The quickflow ratio in SIMHYD is the modelled surface runoff (IRUN + SRUN, in Figure 1) divided by the modelled total runoff (IRUN + SRUN + BAS). An automatic pattern search optimisation technique is used to calibrate the model, with a number of different parameter sets used as starting points, to increase the likelihood of finding a global optimum.

The calibration is carried out for four model types:

- SIMHYD with all seven parameters [7-par];
- SIMHYD with five parameters (COEFF = 200 and SQ = 1.5 used as default values) [5-par];
- SIMHYD with seven parameters, but with the two months with the largest errors between the modelled and recorded runoffs removed from the dataset (i.e., ignored in calculating the objective function) [7-par, 2-out]; and
- SIMHYD with five parameters, with the two months with the largest errors removed [5-par, 2-out].

SIMHYD simulates little to no infiltration excess runoff in most catchments (except for tropical catchments), and therefore the optimisation of COEFF and SQ is not required in most catchments. Removing the two largest errors provides an opportunity to ignore potential large errors in the data (possibly due to difficulties in rating the very high flows). The calibration against monthly runoff, the use of the two constraints in the model calibration, the use of five instead of seven parameters and the removal of the two largest errors increase the likelihood of the optimised parameters taking meaningful values.

The Nash-Sutcliffe coefficient of efficiency (Nash and Sutcliffe, 1970), E, is used here as a measure of the model performance. The E value describes the agreement between all the modelled and recorded monthly runoffs, with E=1.0 indicating that all the modelled monthly runoffs are the same as the recorded runoffs. In general, E values greater than 0.6 suggest a reasonable modelling of runoff and E values greater than 0.8 suggest a good modelling of runoff for catchment yield studies (Chiew and McMahon, 1993).

The distributions of the E values in Figure 3 summarise the SIMHYD calibration results for the 293 catchments for the four model types. The calibration results for the 7-parameter model are only slightly better than for the 5-parameter model, with E values of up to 0.05 higher. The calibration

results are also slightly better when the two largest errors are removed (E values of up to 0.05 higher). The results generally indicate that SIMHYD can be calibrated satisfactorily to reproduce the monthly recorded runoffs, with E values greater than 0.7 obtained in more than 90% of the catchments.

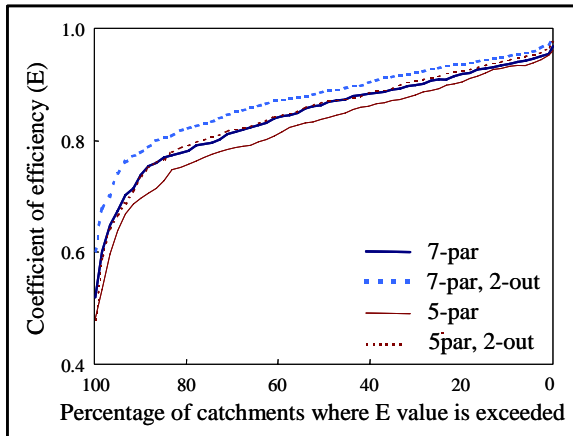

**Figure 3.** Distribution of E values summarising SIMHYD calibration results for the 293 catchments for the four model types

## 5. MODEL REGIONALISATION

Figure 4 shows the correlations of the linear regressions between the optimised SIMHYD parameter values versus each of the six catchment characteristics described at the end of Section 3. In calculating the correlations, only catchments with E values greater than 0.7 in the model calibration are used (271 catchments in the 7-par model; 281 in the 7-par, 2-out model; 257 in the 5-par model; and 269 in the 5-par, 2-out model).

The results indicate that the correlations are higher for the 5-parameter model compared to the 7-parameter model. This is because models with fewer parameters have smaller cross-correlations between the parameters leading to a better definition of parameter values in the model calibration. This highlights the importance of using the simplest model possible for a particular objective, and for applications where catchment water yield estimates are required, the use of models with four to eight parameters should be sufficient. The results also indicate that the correlations are similar, regardless of whether the two largest errors are ignored in the model calibration.

For the reasons above, the remainder of this paper presents only results from the 5-parameter SIMHYD model with all the data used for model calibration.

Table 1 shows the range of SIMHYD parameter values, Table 2 shows the cross-correlations between the optimised parameter values and Table 3 shows the correlations between the parameter values and catchment characteristics. Figure 5 shows each of the parameters plotted against the catchment characteristic to which it is most highly correlated with.

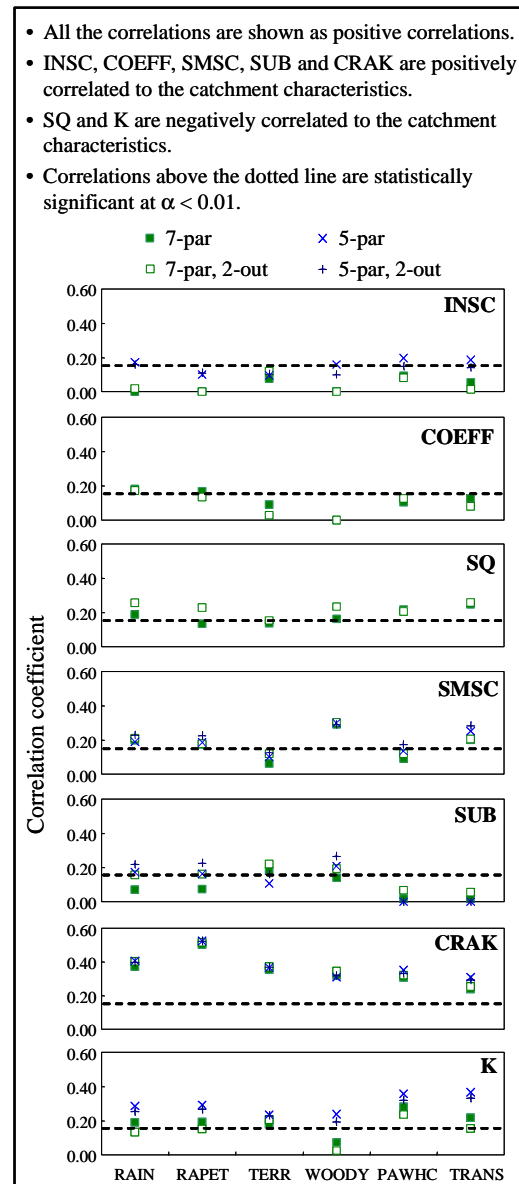

**Figure 4.** Correlations between optimised SIMHYD parameter values versus various catchment characteristics for the four model types

The groundwater recharge parameter, CRAK, followed by the baseflow recession parameter, K, has the highest correlations against the catchment characteristics (Table 3). The correlations between CRAK and all the catchment characteristics are generally higher than those of the other parameters. In particular, the relationship between





